

**ENGINE COOLING AND  
AIR-CONDITIONING  
FOR COMMERCIAL VEHICLES  
AND INDUSTRY**



### The HAUGG COOLING GROUP – joint competence and know-how

HAUGG Kühlerfabrik, HAUGG Industriekühler and Schwarzwälder Metallwarenfabrik HAUGG are dynamic companies of the HAUGG Group. The group of companies bundles comprehensive industrial and branch competence in the process of removing heat. The group's activity is focused on the development, production and sale of heat exchangers in different fields of application for utility vehicles and industry.



The companies of the HAUGG Group are cooling experts for construction and agricultural machinery, compressed air cooling, power stations and rail vehicles – based on a century of experience in the radiator industry.

### OUR PHILOSOPHY

#### Firm principles – the base of a trusting business connection

For HAUGG progress has the meaning of performing the individual wishes and needs of the customers.

- Flexibility
- Quality
- Innovation

Fair prices, adaptable delivery times, professional implementation of all orders and comprehensive service are our goals. Technically highly efficient systems such as vacuum brazing furnaces and contemporary management give the possibility to achieve these goals. We build high-quality products and offer our customers comprehensive, specific solutions.

## The HAUGG Group – Structure and Production Plants



### *Marketing Organisation*

- HAUGG Cooling SRO  
SK/CZ/HU/HR

### HAUGG Cooling Systems – small sizes and large capacity range

The special merits of HAUGG Cooling Systems are small sizes, a large capacity range, low weights as well as a high internal pressure stability.

For light metal standard cooling systems, a plate and bar construction has been chosen for the core, being brazed according to a special flux-free vacuum brazing process. Flux-free means no corrosive residues on the product after brazing while the plate and bar design grants high pressure stability. 15 different basic cooling systems with numerous variations are available.

This allows us to select the optimum cooling system suitable to numerous applications at a reasonable price.

In total, the production programme encompasses:

- Complete cooling systems and cooling modules
- Charge air and water coolers for mobile and stationary applications
- Compressed air and combination coolers
- Oil coolers for hydraulic units, gears and vehicle engines
- Heat exchangers in aluminium, non-ferrous metal and steel
- Ventilation units with electric and hydraulic motors
- Radiator repair

Heat exchangers like evaporators, condensers, heaters and blowers make up our range of products for interior climate control.

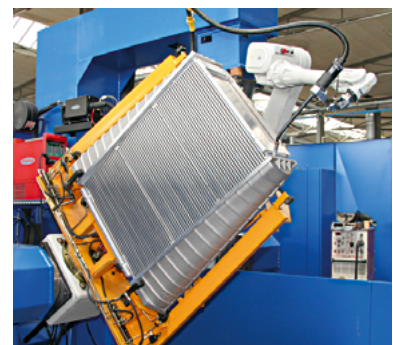
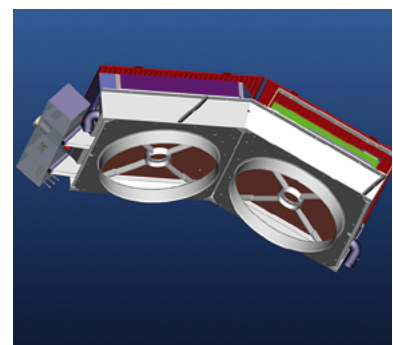
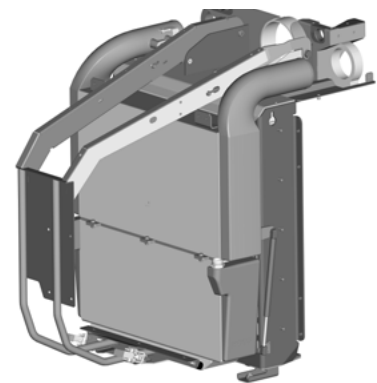



# COOLING SYSTEMS FOR CONSTRUCTION MACHINES AND AGRICULTURAL VEHICLES

## HAUGG – about a century of experience in cooling

Machines are used in different climate zones of the planet. Moreover, loaders or hollow tippers, tractors, combine harvesters or seeding machines demand top cooling performance and no system clogging. For construction and agricultural machinery HAUGG develops complete cooling systems and modules, single components for engine cooling and interior air-conditioning components.

Thanks to our competence in the layout, design and construction of heat-exchangers and about a century of experience we provide expert solutions – also for extreme environmental conditions. Moreover, we strive to develop new solutions for future demands.

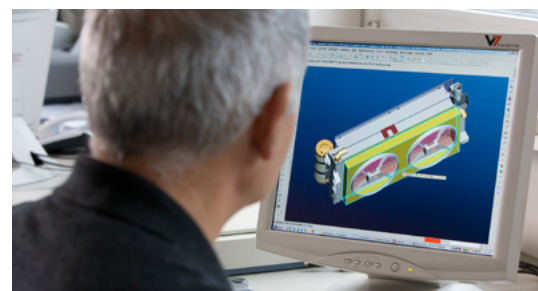

# COOLING SYSTEMS FOR RAIL VEHICLES

## HAUGG has been building cooling units for trains since 1999

More stringent demands placed on cooler designs like low weight coupled with high power density and increased need of security, made the use of aluminium indispensable for heat exchangers.

To increase durability of the coolers HAUGG established cathaphoretic painting. Comprehensive tests at Deutsche Bahn AG approved good resistance against all solvents.

The resulting high power density and the flexible dimensioning, facilitate a design that can be adapted to the respective operating conditions and installation criteria.

The methods used for calculating the design's thermodynamic properties are based on extensive experiments. In addition, the design also benefits from experience gained from field installations.



## Punching and deep drawing – tailor made

The large scope of production possibilities includes punching and deep drawing of all sorts of metals. Even highly complex deep drawn parts are manufactured according to drawings or samples with highest precision and efficiency.

Our products are installed in the electric, electronic and automotive industry, heating systems, instrumentation, cosmetics and medical industry etc.

Starting point of the production is a metal strip:

- copper
- brass
- bronze
- steel
- stainless steel
- aluminium

The eccentric presses have the capacity of forming parts out of metal strips up to 200 mm width and gauges up to 5 mm. On stage presses we start with discs in diameters of 80, 120 or 160 mm and strip gauges of up to 2 mm.





## Thin sheet metal processing – from single parts to middle series

We supply metal parts, formed through punching, bending, drawing, pressing, moulding or CNC-manufactured. We achieve tolerances of  $\pm 0.1$  mm in welded constructions and are able to process all types of metals including

- steel,
- stainless steel,
- aluminium,
- brass,
- copper and
- materials that are metal coated including zinc.

We have the ability to process steel metal up to 6 mm thickness and stainless steel up to 4 mm.

Complete assemblies are manufactured, from single parts to middle series:

- linings of all kinds
- housing and doors
- control panels and tubular mountings
- hoods and frame covers

We supply manufacturers of kitchen appliances, automotive industry, mechanical engineering, electrical and electronic equipment manufacturers and the furniture industry.

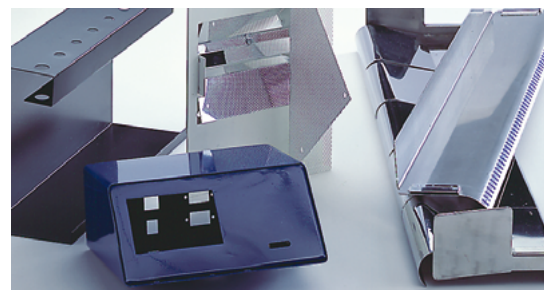



## Innovation and quality – the driving forces of the HAUGG Group

The success of the HAUGG Group is based on innovation and quality. With our management system we set the standard for an enterprisewide project and quality management. In 1997 HAUGG was the first manufacturer of coolers who switched the main production process to the environment-friendly, economical and increased quality vacuum brazing.

The HAUGG Group is certified according to DIN ISO 9001-2008. Additionally in 2003 we obtained the approval for welding in rail-mounted vehicles according to DIN 6700 C2 and updated 2010 according to DIN EN 15085 CL1.

Since 2016 HAUGG has been using the environmentally-friendly energy management system DIN 50001. Both the development, production and assembly of heat exchangers, cooling modules and their components, as well as the production of sheet metal, punched and deep drawn parts, have optimized the processes and sustained the energy efficiency of the company to improve.



## The service network – flexible, fast and throughout Europe

HAUGG Group's service network is throughout Europe. We also take over spare parts or repair service for our customers.





**CERTIFICATE**

This is to certify that

**HAUGG-Gruppe**  
**Haugg Kühlerfabrik GmbH**  
 Reichsweg 46  
 52088 Aachen  
 Germany

with the organizational sites as listed in the annex  
 has implemented and maintains a **Quality Management System**

Scope:  
 design, manufacturing and assembling of heat exchangers and cooling modules and their components - as well as sheet metal treatment, punched and deep drawn parts

Through an audit, documented in a report, it was verified that the management system fulfills the requirements of the following standard:

**ISO 9001 : 2008**

Certificate registration no. 286385 QM08  
 Valid from 2015-10-14  
 Valid until 2018-09-14  
 Date of certification 2015-10-14

**DQS GmbH**  
*G. Blechschmitt*  
 G02: Blechschmitt  
 Managing Director

Accredited Body: DQS GmbH, August-Schanz-Straße 21, 60433 Frankfurt am Main, Germany

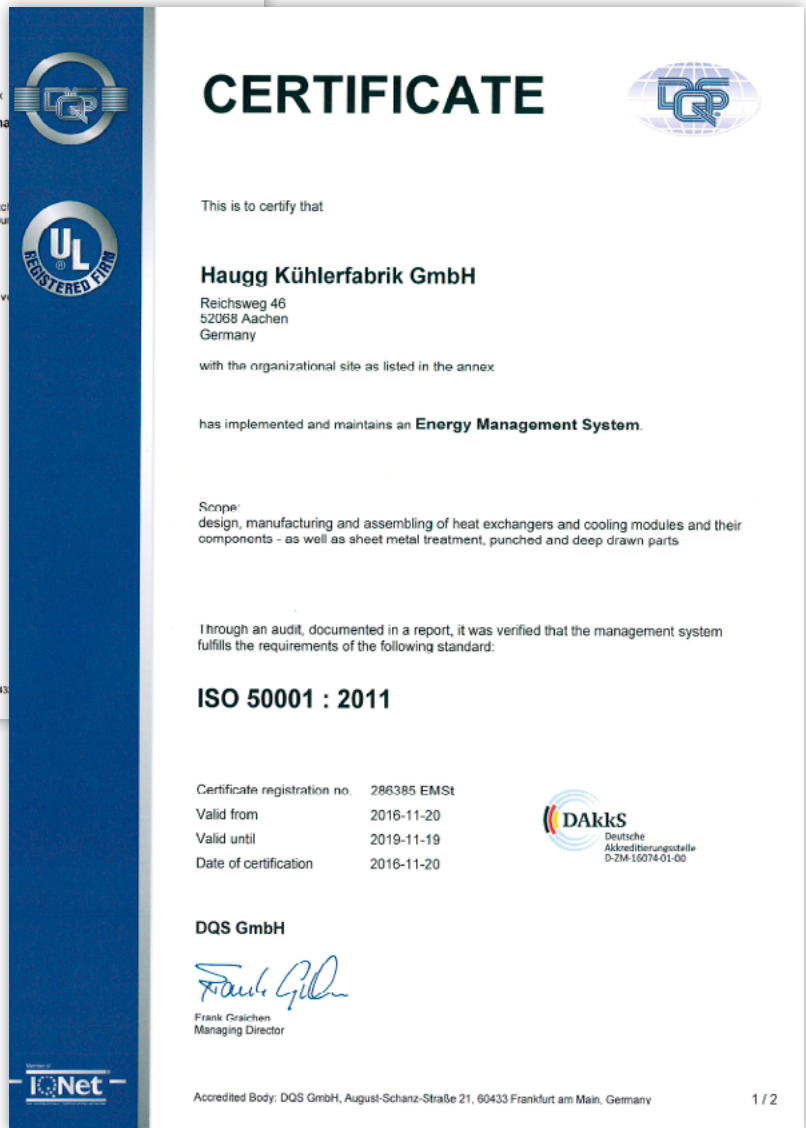

**CERTIFICATE**

This is to certify that

**Haugg Kühlerfabrik GmbH**  
 Reichsweg 46  
 52088 Aachen  
 Germany

with the organizational site as listed in the annex  
 has implemented and maintains an **Energy Management System**.

Scope:  
 design, manufacturing and assembling of heat exchangers and cooling modules and their components - as well as sheet metal treatment, punched and deep drawn parts

Through an audit, documented in a report, it was verified that the management system fulfills the requirements of the following standard:

**ISO 50001 : 2011**

Certificate registration no. 286385 EMSt  
 Valid from 2016-11-20  
 Valid until 2019-11-19  
 Date of certification 2016-11-20

**DQS GmbH**  
*Frank Graichen*  
 Frank Graichen  
 Managing Director

Accredited Body: DQS GmbH, August-Schanz-Straße 21, 60433 Frankfurt am Main, Germany

1 / 2

Certificate no.: TÜV SÜD/15085/CL1/175/3A1/03

**Comments:**

The welding coordinator Mr. Bernd Wössner is allowed to perform welder and welding operator qualification tests acc. to EN 287-1, EN ISO 9606-2 and EN 1418.

**General regulations**

according to EN 15085-2

**Revocation of the Certificate**

The national safety authority or the manufacturer certifi may revoke the certificate if:

- there are justified doubts as to the proper execution of standards,
- there are justified doubts as to the proper welding coc standards,
- no recognized welding coordinator is available any lor standards are available,
- no valid qualification test certificates for the welders a standards are available,
- welders or welding operators without tested qualificati of welding work under the stated standards,
- other conditions according to the stated standards are
- the manufacturer certification body was refused an op
- the welding manufacturer waives the certificate

The welding manufacturer shall acknowledge the revoc body. The manufacturer certification body shall notify tr

If a valid certificate is to be renewed, the renewal must body at least **two months** before the end of the period

**Distribution list:**

1. Applicant (original)
2. Files

2 of 2

ZERTIFIKAT ◆ CERTIFICATE ◆ CERTIFICADO ◆ CERTIFIKAT ◆ 認 証 証 書 ◆ CERTIFICATE ◆ ZERTIFIKAT

TÜV SÜD Industrie Service GmbH



Industrie Service

**CERTIFICATE**  
Welding of railway vehicles and components according to EN 15085-2

This is to certify that **HAUGG-INDUSTRIEKÜHLER GmbH**

**Bahnhofstrasse 84-88**

**D-72172 Sulz / Neckar**

is qualified to perform welding work within the range of certification of:

**Certification level CL1 according to EN 15085-2**

**Field of application:** • New build of rail vehicles and their components  
- coolers, heat exchangers, ventilation units, supporting frames  
- with design, purchase, resale and assembly

**Range of certification**

Welding process according to DIN EN ISO 4063	Material group according to CEN ISO/TR 15608	Dimensions	Comments
131	22/24 24 23	t = 3 - 10 mm t = 3 - 12 mm t = 3 - 20 mm	BW, FW: t = 3 - 12 mm - -
135	1.2	t = 3 - 12 mm	BW, FW: t = 5 - 12 mm
141	22/24 23 24 1.2/8	t = 3 - 10 mm t = 3 - 12 mm t = 3 - 12 mm t = 5 - 12 mm	BW, FW: t = 3 - 12 mm - FW FW

**Responsible welding coordinator:** Bernd Wössner (IWE) born: 05.11.1967

**Deputy with equal rights:** -

**Deputy:** Joachim Eisenack (IWS) born: 21.07.1958

**Comments:** see reverse

**Certificate no.:** TÜV SÜD/15085/CL1/175/3A1/03

**Valid:** from 31.07.2013 to 31.05.2016

**Issued on:** 31.07.2013

**Auditor:** HAUG  
General regulations (see reverse)

*C. Lecca*

Lecca  
head of certification body

